

APOLLO-35

Electric Speed Controller for Brushless
Sensorless motor



A new generation of high-performance, brushless, sensorless DC Motor Speed Controller — with easy-to-use features and countless innovations!

The new Apollo 35 have the most demanded features, such as:

1. Easy programming using a programming card
2. Very low impedance to deliver better efficiency
3. Dual BEC to support 3S LiPo batteries in helicopter applications
4. LiPo battery protection at low voltage warning and auto cut-off
5. Ability to support 6S LiPo high-voltage applications



Detailed Features:

- Extremely low resistance (.0048 ohms)
- High rate (12 kHz) switching (PWM)
- Up to 35 amps continuous current with proper airflow — 50 amps surge for 15 seconds
- Dual Battery Eliminator Circuit (BEC) provides 2.0 amp stable, continuous power for your receiver and servos
- Handles 5-8 cells with five micro servos
- Handles up to 10 cells with three micro servos
- Handles up to 12 cells with two micro servos
- Handles high-voltage applications up to 25V maximum with 6-cell LiPo batteries (BEC disabled)
- Dynamic braking ensures that folding props fold promptly
- High-temperature protection circuit
- LiPo/Li-Ion battery low voltage protection design
- Easy programming with programming card
- User-programmable features: Brake Type (ON/OFF); Low Power Cut-Off (LiPo auto/5V); Motor Timing (Auto/Low/Standard/Advance)
- Runs motor in forward OR reverse
- Motor auto cut-off with reset

- Safe “power on” arming program prevents motor from turning on accidentally
- Low torque “soft start” prevents damage to fragile gearboxes
- Shuts down power automatically when signal is lost or radio interference becomes severe
- Hi-Speed Microprocessor controlled
- Surface Mount Technology (SMT) on the controller and programming card ensures high-quality operation

How to use the ESC:

This is a controller for a DC brushless and sensorless motor.

A signal line composed of three color thin wires comes out on one side of the ESC, along with two power lines. On top of the ESC, you will find clear positive and negative signs. The signal line should connect to the throttle control of your receiver. The power line should connect to the battery. Be sure to connect the positive red wire to the positive side of the battery.

On the other side of the ESC are three wires that should connect to your brushless, sensorless motor. You may connect these three wires as you wish. No specific order is necessary. Exchanging the connection of any two wires will cause the motor to turn in the reverse direction.

The ESC may trigger the motor to generate certain tones which feed back to the user about the setting or confirmation. You need to connect the motor to have those tones.

*** Warning: The red wire of the power line should connect to the positive side of your battery, and the black wire of the power line should connect to the negative side of your battery. Connecting these wires incorrectly will burn out the ESC, and the damage will not be covered by the warranty. Double-check your connections is important to the ESC and your safety!**

ESC Programming Procedure:

- 1) Disconnect the battery connector from the ESC.
- 2) Connect the Signal line to the programming card first;
- 3) Then, connect the battery connector to ESC. The ESC will respond with a beep!
- 4) Now you may start to program the ESC by pressing the button.
- 5) Once you have pressed the button, the ESC will respond with 1 to 8 beeps to represent different functions. The ESC will remember what has been set after you pressed the button.
- 6) Disconnect the battery connector and signal line from ESC.
- 7) Connect the signal line to receiver throttle control and you are done programming.

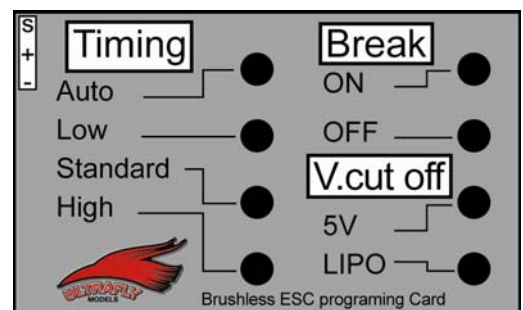

Now you can start to use the ESC by connecting the battery connector to your battery.

How to program the ESC:

The Apollo is a very intelligent ESC that handles most functions automatically. You may, however, change the configuration of the following functions:

- Brake
- Timing
- Cut-off Voltage

Before making changes, read through each section below so that you understand how to configure the ESC.

Brake

Brake is usually used with a glider model. It will force the folding prop to stop, causing it to fold in the air and reduce drag. Pressing the "ON" button will activate the brake.

Cut-off Voltage

When using NiCd or NiMH batteries to fly, some battery power must be reserved for the receiver and servos so that it is not all consumed by the motor. With that reserve power, the airplane can be landed safely.

For this reason we set a power cut-off voltage at 5V. Once battery voltage reaches 5V, the ESC cuts off power to the motor — but will still supply current to the receiver and servos.

In normal flight, you'll notice when power is getting weaker and weaker. This tells you that it's time to land your aircraft. If you continue to fly, the battery will soon reach the cut-off voltage. When voltage cut-off is activated, you can reset the ESC by putting your throttle back in zero position. Then you can slowly advance the throttle stick to regain a little power for landing the model as quickly as possible.

If you fly with a NiCd or NiMH battery, you'll notice that the motor becomes weak before the cut-off voltage is reached. In a LiPo or Li-Ion battery application, the battery will not function properly if you allow its voltage to drop below 2.4V per cell. You may not notice any weakening of power until it is too late.

When you select its LiPo mode, this ESC will detect the battery voltage and calculate the cut-off voltage automatically. Cut-off voltage will be set to 2.6V per cell. When voltage per cell drops to 2.9V, the ESC periodically reduces power to 50% as a warning before cutting off power. This two-step cut-off design will help you recognize when it is time to land your aircraft.

Timing

This ESC has a very fast CPU so that you can use Hi-timing for almost all the motors in the market. The Hi-timing will milk out more power from the power system but the back side is lower efficiency. For 90% of the motors you use, the ESC's auto timing mode will be perfect in efficiency consideration. If you discover that a particular motor is not running smoothly or not

performing well, you may change the timing and try to find a better fit for that specific motor.

There's no solid rule to setting the timing for a specific type of motor. The best method is trial and error. Just set the different timing and then hook up the power to feel the difference. Different timing will not harm the motor, but in certain situations it could boost up the power by 20-30%. That might cause the motor to exceed its maximum power or maximum rpm — or cause the ESC to reach overload or over current! Either could possibly harm the motor or the ESC. So, speed up gradually to test the power after you change the timing.

Throttle Reverse in certain Radio system

There are many different RC Radio systems in the market. For the throttle control, maximum power in certain radio system could be the low position. You need to set up the radio throttle control to reverse so that you may use the ESC correctly.

Start to use the ESC & Arming the ESC

The ESC will not drive the motor until you arm the ESC. This is a protection design. You have to move the throttle stick to its low position so that you can arm the ESC after you connect the battery to ESC. Once the ESC has been armed you will hear three rising tones.

Throttle Calibration

The throttle range in different Radio system is also different. In certain Radio system, the throttle range is not corresponding to the ESC throttle range. If this can not match, you may encounter two problems. (1) You can't arm (start) the ESC (2) You can reach its maximum power when the throttle stick is already in its upper top position. At this moment, you need to re-calibrate your ESC to match its throttle range to the transmitter you are using.

Here is the procedure to reset the throttle range in the ESC. We this "Throttle Calibration"

- 1) Move the transmitter throttle stick to the upper most position. Turn on the transmitter power.
- 2) Connect the ESC to the receiver throttle channel then connect the battery to the ESC. You should hear the ESC triggering the motor to have 4 single tones. Now, It is in the throttle calibration mode.
- 3) Move the throttle stick to the low position for 2 seconds then you should hear the ESC triggering the motor to have one long and two short tones. It's done!
- 4) You can disconnect the battery and reconnect it to start using the ESC.